

External Exhaust Valve

For Sentinel C-20, B-21, I-21 and F-21 Instruments

APPLICATION BULLETIN #138

October, 2002

For some applications it is desirable to utilize an external exhaust valve to:

- Minimize part contamination from reaching the instrument's internal pneumatics after testing
- Quickly release the pressure from the part after test

The Sentinel instruments have outputs that can be setup for this function.

Sentinel C-20 instruments

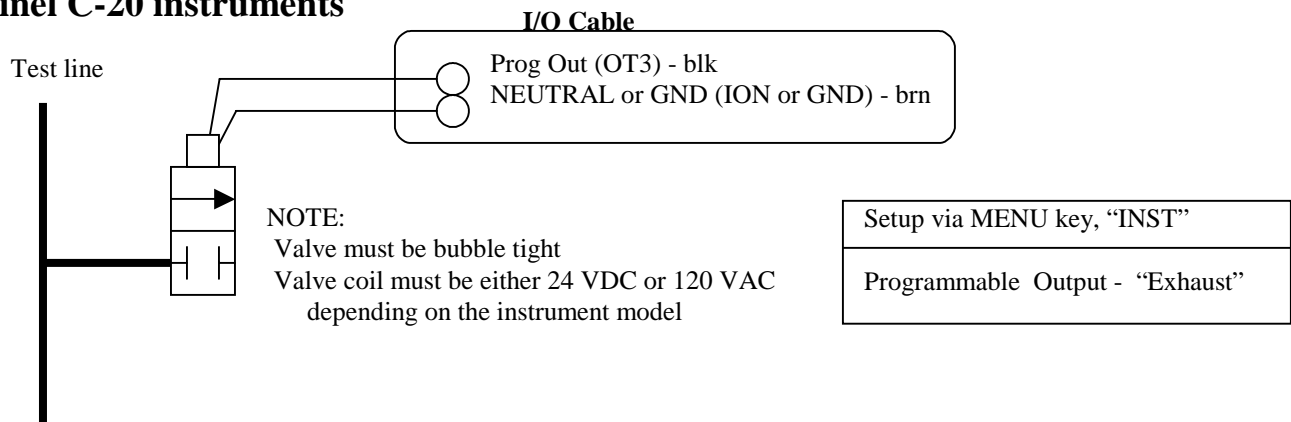

Sentinel B-21, I-21 and F-21 instruments

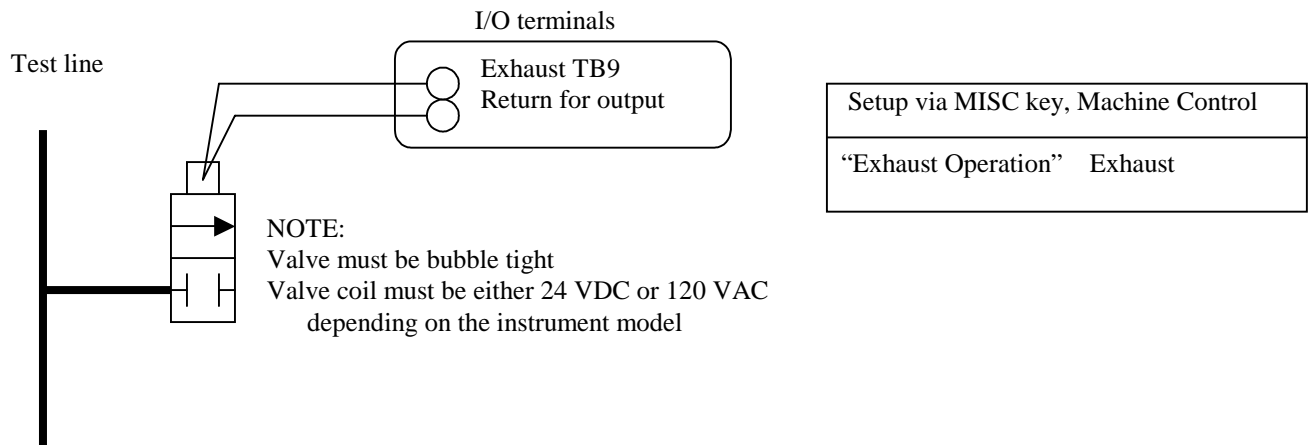

Cincinnati Test Systems, Inc.

Member of TASI - A Total Automated Solutions Inc. Company

5555 Dry Fork Road, Village of Cleves, OH 45002 • Tel. 513-367-6699 • Fax 513-367-5426

Website: www.cincinnati-test.com • E-mail: sales@cincinnati-test.com